

Bin Vent/Dust Collector

Cyclonaire Bin Vent/Dust Collectors provide excellent filtration at destination points such as bins, hoppers and silos. Automatic timers clean the filter media with pulse jet reverse flow air, dropping retained material back into the process. Bin Vent/Dust Collectors are designed to handle any dry bulk material conveyed pneumatically.

Peak Performance – Pulse jet cleaning assures media effectiveness.

Service Alerts – Differential pressure gauges for filter service indication.

Easy Installation – Flanged outlet and dust discharge ensure quick installation.



Standard

Robust 10-Gauge Carbon Steel Construction; 24 VDC Controls; NEMA 4 Type Enclosure; Differential Gauge; Bottom-Removable Pleated Filter Element; Filter Grid; Bird Screen on Exhaust Outlet; Cyclonaire Blue paint

Standard Options

PTFE-Coated Filters; Differential Pressure Switch, Differential Pressure Transmitter; Back Purge of Differential Available; 304 Stainless Steel Material Contact; Cyclonaire White Paint; 120 VAC Controls; High-Temp Filters; Flange and Orientation on Exhaust Outlet; Adaptable for Fan Usage; Autonomous DP Switch Control

Custom Options

316/ 316L Stainless Steel Material Contact; Surge Hopper; Top-Removable Filters with Access Platforms; Explosion Protection; Classified Area Enclosure; Custom Colors/Coatings Available; Broken Bag Detector; Autonomous (DP Switch) Control; Process Pressure Monitoring

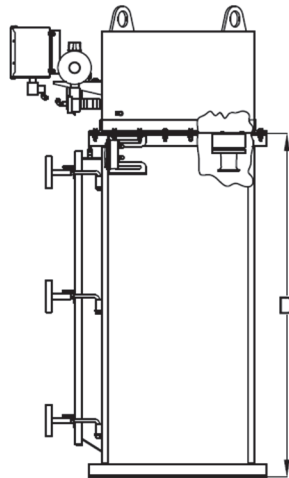
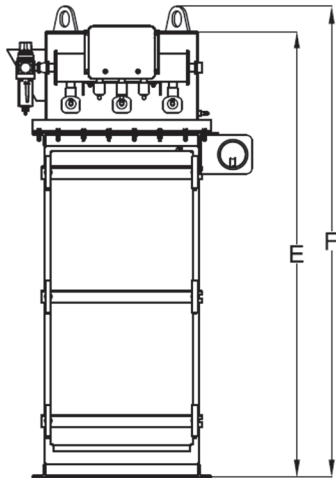
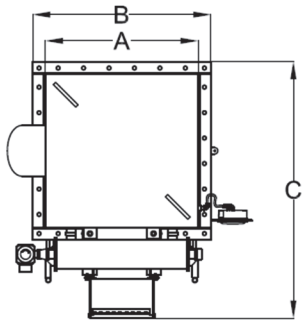

Managing air quality is extremely important in plants and facilities that use dry solids.

Cyclonaire Bin Vent/Dust Collectors are the first step in the filtration process to contribute to a safer, cleaner work environment. Investing in a complete filtration process helps operations run smoothly without frequent maintenance or shutdowns, saving time and money.

We offer the most advanced filter media with cleaning processes that consistently maintain the unit's peak performance. Automatic timers clean the filter media with pulse jet reverse flow air, dropping retained material back into the process.

These units can be incorporated into any pneumatic conveying system.

	Filter Area	Max. Air Flow Recommended	A	B	C	D	E	F	Approx. weight
Model	[ft ²]	[cfm] x surge	[in]	[in]	[in]	[in]	[in]	[in]	[lbs]
36-DC-4	94.8	284	16	20	33	54	68	73	424
36-DC-9	213.3	639	24	28	40.5	54	70	75	638
36-DC-16	379.2	1137	32	36	49	54	70	75	873
36-DC-25	592.5	1777	40	44	63	54	70	75	1195
36-DC-36	853.2	2559	48	52	71	54	70	75	1535
36-DC-49	1161.3	3483	56	60	79	54	70	75	1999
36-DC-64	1516.8	4550	64	68	87	54	72	77	2770
36-DC-81	1919.7	5759	74	78	98	54	72	77	3316

Standard Filters: Pleated Filter Element

Filter area listed assumes standard filter sizes. Use of different filter media may effect these values

Dimensions and weights are subject to change without notice

Keep it clean(er) with our Bin Vent/Dust Collectors. [Contact sales@cyclonaire.com](mailto:sales@cyclonaire.com)

cyclonaire
pneumatic conveying solutions

(800) 445-0730 | cyclonaire.com