

Bulk Bag Filler

Cyclonaire's Bulk Bag Filling Station is the most flexible, customizable choice for your demanding needs and a cost-conscious budget. Start with our standard heavy-duty carbon steel box tubing frame, custom built to handle any weight or size bulk bags.

Custom features include: Bag Inflator, Electronic Scale, Adjustable Height Loop Support Arms, Integral Dust Collection/Suppression System or Vibration/Compaction System, plus more. Quality, custom built at competitive prices.

Applications - Dust collection and other low volume bulk bag filling processes.

Capacity - Designed for standard bulk bag sizes, with adjustable height to accommodate multiple volumes.

Benefits and Features - Supports and seals any size/style bulk bag: Heavy-duty welded tubular steel frame; Forklift access for palletized bulk bags; Bag loop support arms; Flanged inlet for connection to source outlet; Fill spout with annular bag vent; Inner chamber for product flow; Outer chamber for displaced air venting; Vent stub for connection to optional dust collection system; Dust-tight inflatable bag spout seal.

Materials - Any free-flowing dry material that can be stored in bulk bags.

Standard

Carbon steel frame and material contact surfaces; Flanged material inlet; NEMA 4 controls; Inflatable bag spout seal; Remote dust collection connection

Standard Options

304 Stainless Steel material contact surfaces; Adjustable height to meet multiple bag sizes; Material inlet valve; Floor scale for bag weighing and inventory; Integral dust collection/suppression

Custom Options

316 Stainless Steel material contact surfaces; Specify: Stainless Steel; Bag Inflator; Electronic Scale for bag weighing; Adjustable Height Loop Support Arms; Integral Dust Collection/Suppression System; Vibration/Compaction system; Other material inlet connections. (i.e. grooved pipe, plain pipe, etc.)



Requirements - Compressed air for bag spout seal; Electrical 110V or 24V.

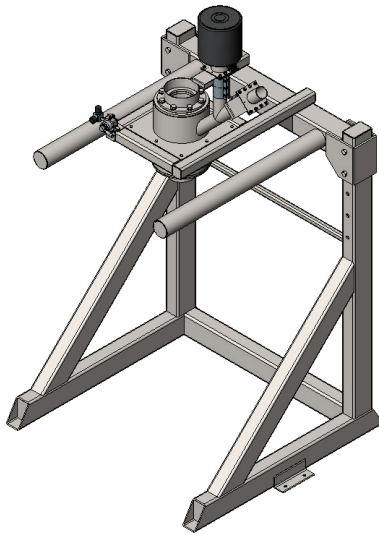
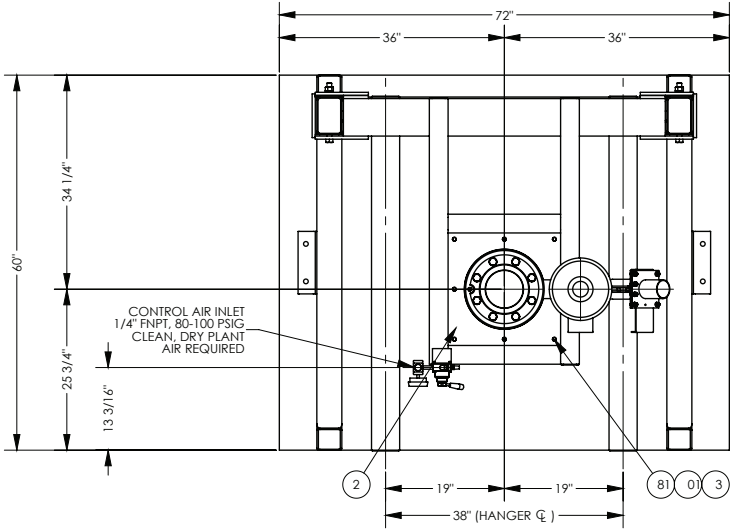

Cyclonaire Bulk Bag Filler

Contact sales@cyclonaire.com.

cyclonaire
pneumatic conveying solutions

(800) 445-0730 | cyclonaire.com