



CHANTLAND

P V S

Material Handling Solutions

POWDERMATIC VALVE AIR PACKER

MODEL 4210

Hheavy-duty gross weighing pneumatic bagger for filling valve type bags with powdered, granular, flakes or pelleted materials.

DESIGN FEATURES:

- Speeds up to (8) 50 lb. bags per minute.
- Accuracies of +/- 1/4 of 1% on load cell models obtainable with good product flow and consistent bulk density.
- 25 lb to 110 lb weight range on bags.
- Contacting surfaces are available in carbon steel or T304 stainless steel.

NOTE: testing may be required to determine obtainable speeds and accuracies on your product.

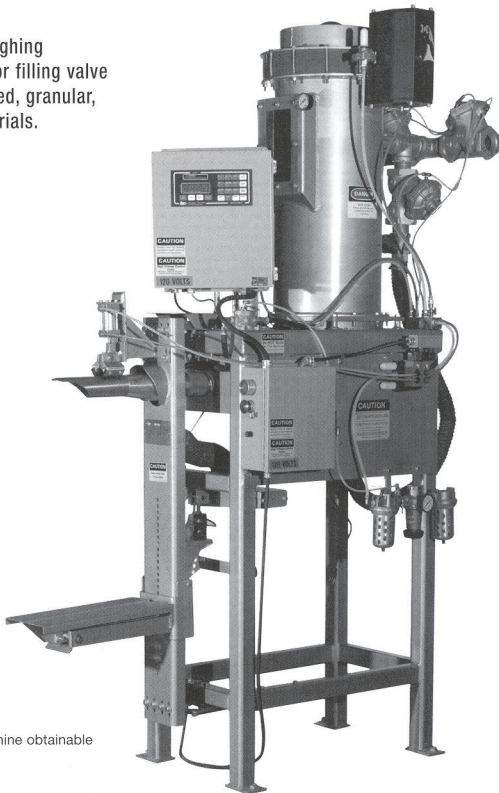

SOLUTIONS

www.chantland.com

PACKERS • CONVEYORS • PALLETIZERS • SYSTEMS

POWDERMATIC VALVE AIR PACKER

MODEL 4210

NOTE: Not all drawings to the same scale

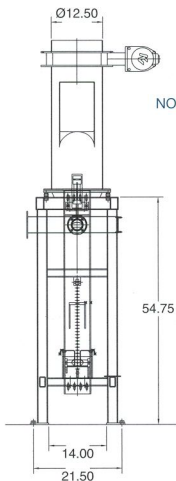

NOTE: Specifications subject to change without notice

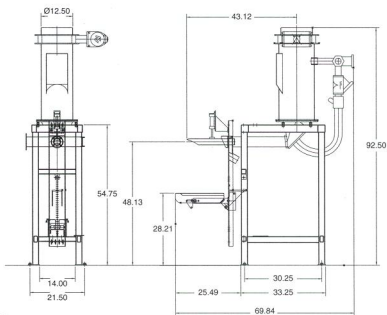
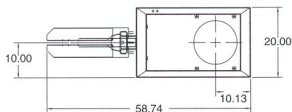

OPTIONS

- CONSTRUCTION: T304 stainless steel on contacting surfaces
- Two- part urethane chemical resistant paint
- Stainless steel paint
- Highly corrosive atmosphere package with anodized cylinders, phenolic bushings, stainless steel fasteners, PVC plastic fittings, stainless steel paint.
- Load cell weighing with preset digital controller
- Auto-start actuator
- Foodgrade construction and polish to meet FDA standards
- Transition hoppers for multiple spout units
- Supply hoppers available in most sizes
- Low-pressure air pump assembly with a positive displacement rotary pump
- UTILITY REQUIREMENTS: 12 cfm @ 80 psi max
- SHIPPING WEIGHT: 1000 lbs
- CRATE DIMENSIONS: 4' w x 6' l x 6' h
- Rotary pump
- UTILITY REQUIREMENTS: 12 cfm @ 80 psi max
- SHIPPING WEIGHT: 1000 lbs
- CRATE DIMENSIONS: 4' w x 6' l x 6' h

STANDARD SPECIFICATIONS:

- CONSTRUCTION: welded tubular steel frame. Mild steel contacting surfaces. One coat metal primer, one coat industrial paint.
- Air-operated bag clamps
- Tilting mechanical bag chair
- Scale-beam weighing on hardened pivot knife edges
- Positive pneumatic air controlled circuitry